

LSKIT-BSC Product Manual

Beale Street Audio Outdoor Speaker Kit with Landscape Subwoofer



Safety Instructions

For optimum performance and safety, please read these instructions carefully before use and keep this manual for future reference. Please have the part number, serial number, and invoice available when requesting support.

- To prevent electric shock, please ensure that all equipment is properly grounded.
- Place the device in a well-ventilated area, do not block any ventilation openings.
- Do not expose the apparatus to an environment that exceeds the product rating.
- Do not place the device on an uneven or unstable surface. The device may fall resulting in a malfunction.
- Never insert anything metallic into the open parts of this apparatus. This may cause a danger of electric shock.
- If a third-party power supply is used, please ensure that the power supply specifications meet the product requirements.

Introduction

The LSKIT-BSC is a complete outdoor speaker system that delivers on value, price, and quality. Each of the WP4V-BSC on-wall/pendant speakers can either be hung, mounted, or planted in the ground with the supplied WPV-LAND landscape accessory kit. The LS10B-BSC 10" downfiring landscape subwoofer completes the system by providing exceptional bass that enhances the audio experience.

Package Contents

4" On-Wall/Pendant Speaker (WP4V-BSC)

- (4) Speakers
- (4) Pendant mounting accessories
- (4) Wall/ceiling mounting accessories

10" Down-Firing Landscape Subwoofer (LS10B-BSC)

- (1) Subwoofer
- (2) wire nuts
- (2) nail stakes
- (1) Security eye bolt

Landscape Accessory Kit (WPV-LAND)

- (4) Base ground plates
- (4) Ground stakes
- (4) Speaker mounts
- (4) Screws and hardware

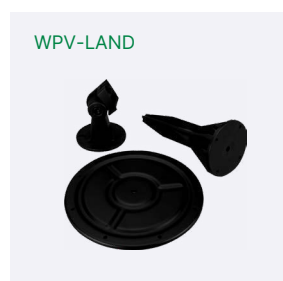
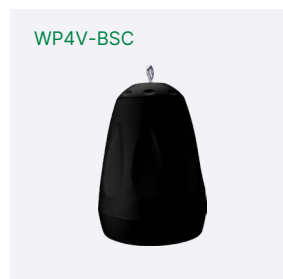

Product Specifications

Specification	WP4V-BSC Speaker	LS10B-BSC Subwoofer
Woofer	4" Polypropylene	10" Polypropylene
Tweeter	0.75" Silk dome	-
RMS power	20W	150W / 300W
Nominal impedance	8 Ohm	4 Ohm
Sensitivity	83dB	86dB
Transformer: 70V	8 Ohm, 1.25W, 2.5W, 5W, 10W	-
Transformer: 100V	8 Ohm, 2.5W, 5W, 10W, 20W	-
Frequency response(±3dB):	(±3dB) 120Hz - 20kHz	(±3dB) 40 - 300Hz
Indoor / outdoor rating	IP66	IP65
Dimensions	5.4" x 7.5" (138mm x 190mm)	12.2" x 16.5" (310mm x 420mm)

Planning the Project

The subwoofer is the heart of the outdoor system. Place it in a position that is as near to the center of the listening area as possible. To increase the perceived bass output, place the subwoofer next to a wall or other reflective surface.

1. Choose the locations for the speakers, subwoofer, and amplifier (not included).
2. Pull a single run of 16-2 stranded speaker wire from the amplifier to the closest speaker and continue the run to the other speakers running in parallel, if being used on a constant voltage system.
3. Pull an additional run of 16-2 stranded speaker wire from the amplifier to the subwoofer.

Note: Leave extra length of wire on each end to allow making connections and installing/removing speakers.

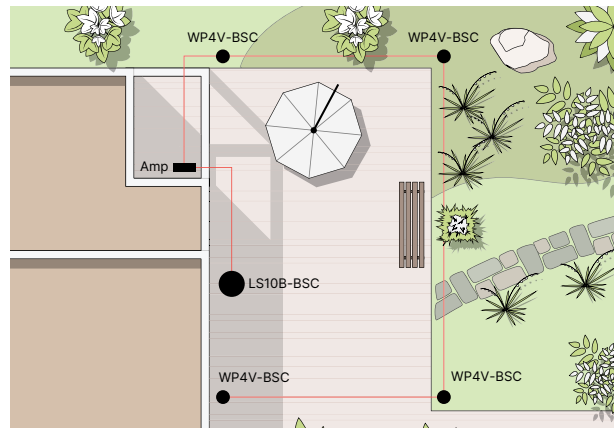

Speaker Wire Recommendations

150ft (46m)	16AWG
400ft (122m)	14AWG

Suggested Amplifiers

BAV2500



1000W, 2 Channel Amplifier Solution

BA2101 and A220



100W, 2 Channel Amplifier Solution

BA251 and A120



50W, 2 Channel Amplifier Solution

Speaker Installation

4" On-Wall/Pendant Speaker (WP4V-BSC)

1. At each speaker location, route the speaker cable through the top cover and dress the cables to the wire rope. Using the provided back cover, slide the speaker cables through the hole in the back cover.

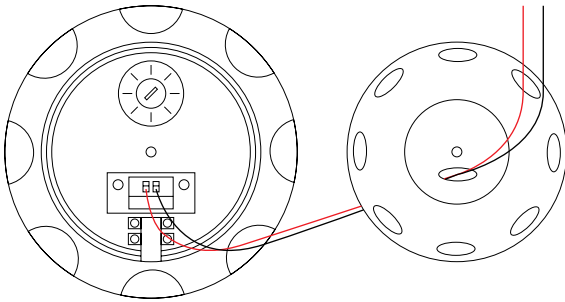

2. Set the tap of the speaker to the appropriate setting.
3. Strip the cable ends approximately 1/8" to 3/16"
4. Connect the wires from the amplifier or previous speaker to the supplied terminal block using the IN terminal (red is + and black is -)

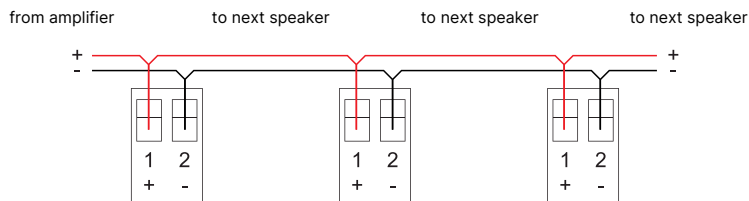

5. See images below for desired mounting instructions.

Hanging option:

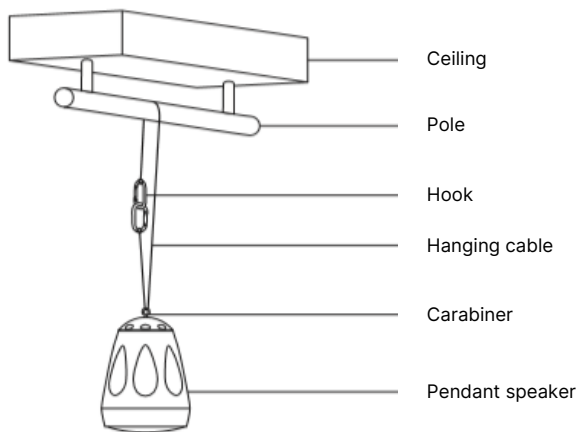

Wall mount option:

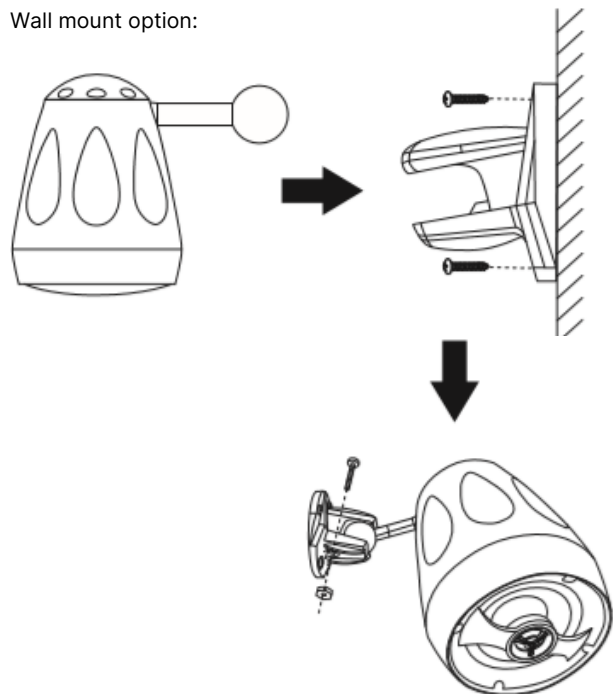

Subwoofer Installation

10" Down-Firing Landscape Subwoofer (LS10B-BSC)

1. Determine the location of the omnidirectional, down-firing subwoofer. Recommend installing the sub within 15ft of the any other landscape full-range speakers. Make sure that the speaker wire is run to the location.
2. OPTIONAL: Measure the center-to-center distance between the key-hole slots and install the two provided panhead nail stakes into the surface, leaving 1/4" of the screws exposed above the surface.

NOTE: different types of surfaces and soil may require different stakes or mounting hardware that is sold separately.

3. Connect the speaker wire run to the subwoofer location to the leads connected to the subwoofer with the provided wire nuts.
4. OPTIONAL: For added security, use the provided security eyebolt to the bottom of the subwoofer and connect to a secure feature locally.

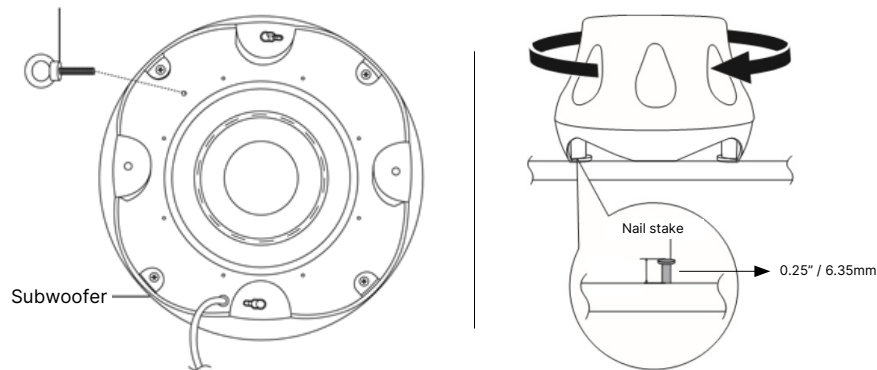

5. OPTIONAL: If you plan to utilize the nail stakes in step 2, place the subwoofer onto the pan head nail stakes and rotate the subwoofer clockwise so that the keyhole slots lock down onto the nail stakes.

Landscape Kit Installation

Landscape Accessory Kit (WPV-LAND)

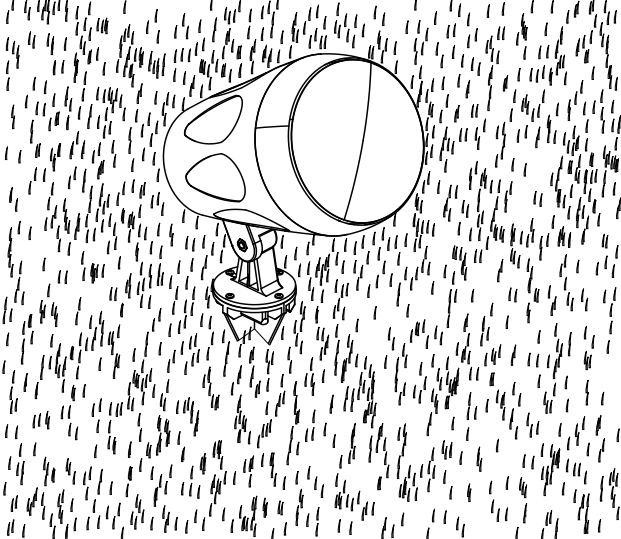
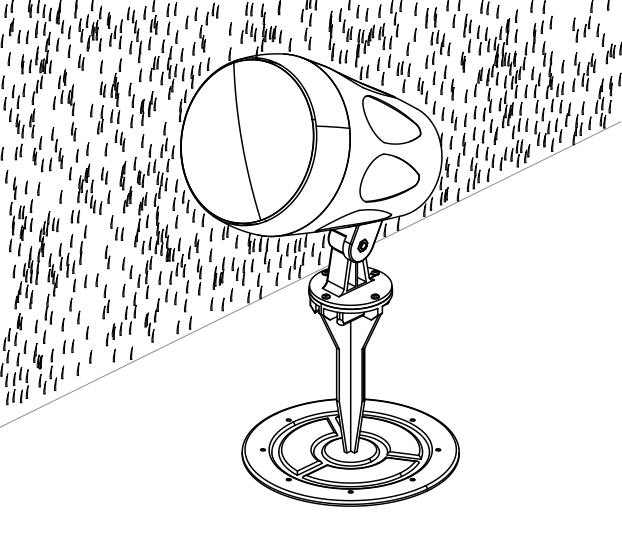
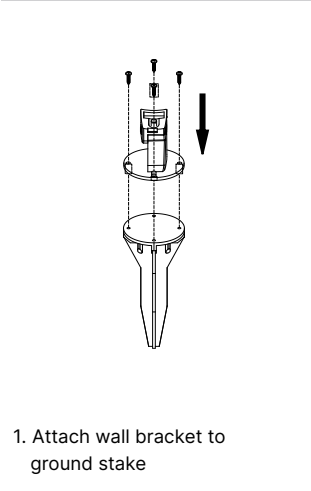
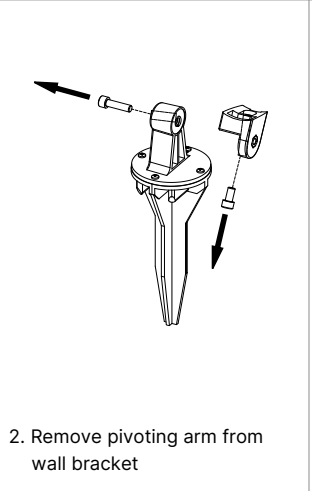
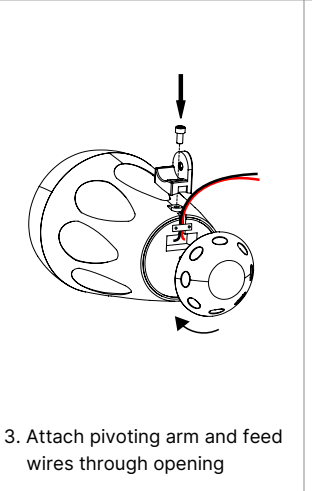
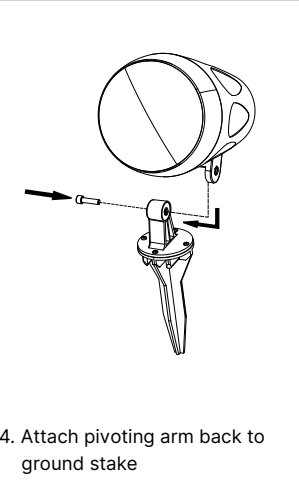
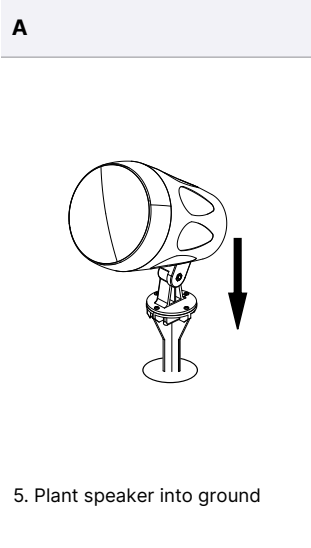
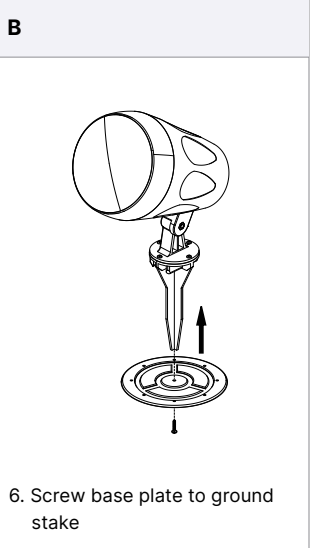
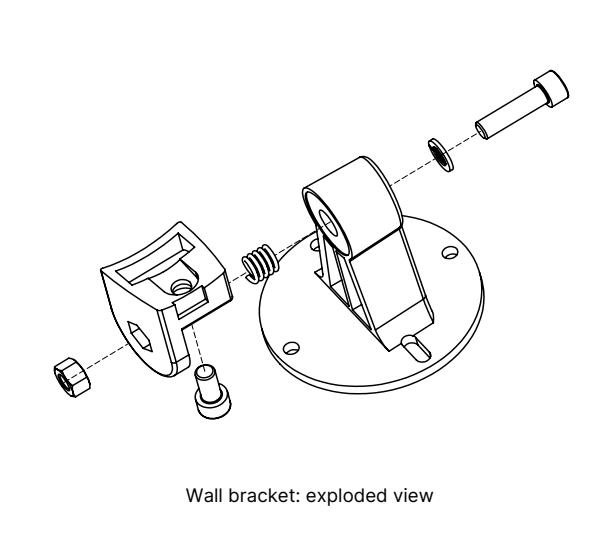
Option A: Ground Stake		Option B: Base Plate	
			
A & B	A & B	A & B	A & B
 <p>1. Attach wall bracket to ground stake</p>	 <p>2. Remove pivoting arm from wall bracket</p>	 <p>3. Attach pivoting arm and feed wires through opening</p>	 <p>4. Attach pivoting arm back to ground stake</p>
A	B		
 <p>5. Plant speaker into ground</p>	 <p>6. Screw base plate to ground stake</p>	 <p>Wall bracket: exploded view</p>	

Limited Warranty

With the exceptions noted in the next paragraph, Vanco warrants to the original purchaser that the equipment it manufactures or sells will be free from defects in materials and workmanship for a lifetime from the date of purchase. Should this product, in Vanco's opinion, prove defective within this warranty period, Vanco, at its option, will repair or replace this product without charge. Any defective parts replaced become the property of Vanco. This warranty does not apply to those products which have been damaged due to accident, unauthorized alterations, improper repair, modifications, inadequate maintenance and care, or use in any manner for which the product was not originally intended.

Items integrated into Vanco products that are made by other manufacturers, notably computer hard drives and liquid crystal display panels, are limited to the term of the warranty offered by the respective manufacturers. Such specific warranties are available upon request to Vanco. A surge protector, power conditioner unit, or an uninterruptible power supply must be installed in the electrical circuit to protect against power surges.

If repairs are needed during the warranty period the purchaser will be required to provide a sales receipt/sales invoice or other acceptable proof of purchase to the seller of this equipment. The seller will then contact Vanco regarding warranty repair or replacement.

Liability Statement

Every effort has been made to ensure that this product is free of defects. The manufacturer of this product cannot be held liable for the use of this hardware or any direct or indirect consequential damages arising from its use. It is the responsibility of the user and installer of the hardware to check that it is suitable for their requirements and that it is installed correctly. All rights are reserved. No parts of this manual may be reproduced or transmitted by any form or means electronic or mechanical, including photocopying, recording or by any information storage or retrieval system without the written consent of the publisher.

Manufacturer reserves the right to revise any of its hardware and software following its policy to modify and/or improve its products where necessary or desirable. This statement does not affect the legal rights of the user in any way. For additional information, please visit www.vanco1.com.

Technical Support

Please read this product manual prior to calling or installing this unit, since it will familiarize you with the capabilities of this product and its proper installation.

In case of problems, please contact Vanco Technical Support by dialing 1-800-626-6445. You can also email technical support issues to techsupport@vanco1.com. When calling, please have the part number, serial number (affixed to the bottom of the unit) and invoice available for reference during the call.

All active electronic products are 100% inspected and tested to insure highest product quality and trouble-free installation and operation. The testing process utilizes the types of high-definition sources and displays typically installed for entertainment and home theater applications.

Vanco Tech Support

Phone: 1-800-626-6445

Email: techsupport@vanco1.com

Web: www.vanco1.com

Please have the part number, serial number, and invoice available when requesting support.

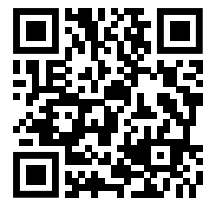

Tech Support