



HOME
THEATER

✓1080p

FullHD

3D
READY

HDMI®
HIGH-DEFINITION MULTIMEDIA INTERFACE



HDMI® Selector Switches

Vanco Part Numbers
280710 (5x1)
280711 (3x1)

Technical Support

www.vanco1.com • info@vanco1.com • 800-626-6445

DEAR CUSTOMER

Thank you for purchasing this product.
For optimum performance and safety, please read these instructions carefully before connecting, operating or adjusting this product. Please keep this manual for future reference.

This product is 100% inspected and tested in the United States to verify HDMI performance parameters.

WARNING

1. Do not expose this unit to water, moisture, or excessive humidity.
2. Do not install or place this unit in a built-in cabinet, or other confined space without adequate ventilation.
3. To prevent risk of electrical shock or fire hazard, due to overheating, do not obstruct unit's ventilation openings.
4. Do not install near any source of heat, including other units that may produce heat.
5. Do not place unit near flames.
6. Only clean unit with a dry cloth.
7. Unplug unit during lightening storms, or when not used for an extended period of time. A surge protector is strongly recommended.
8. Protect the power cord from being walked on or pinched, particularly at the plugs.
9. Use unit only with accessories specified by the manufacturer.
10. Refer all servicing to qualified personnel.

CAUTION

HDMI is a very complex technology requiring continuous authentication of the signal and the same video resolution and audio settings on all electronic equipment in the system. When there are multiple sources and displays, the video resolution and audio setting on all connected units must be adjusted to correspond with that of the display having the lowest video and audio capability.

FEATURES

Super IR Control

These units have the capability of being controlled via IR signals. The switch can be controlled from the display. This is accomplished by using an optional IR Receiver pigtail (Part # 280721) pointing away from the display(s), which can be connected with the optional HDMI IR Adapter (Part # 280703), and inserted between the HDMI cable connector and the display with the toggle switch at the "IR" position. The IR Transmitter pigtail (Part # 280720) is then connected to the switch and pointed at the source(s). A remote control is used at the display to select switch inputs and outputs.

*** These products are only compatible with Vanco's Super HDMI IR Accessories.

Over-Current Over-Voltage Protection

The circuit boards are equipped with both over-current and over-voltage protection and automatically power down if these are encountered. The power circuit will restore itself automatically once the excessive current or voltage conditions are rectified.

HDMI® 5 x 1 Switcher with IR Control

Part # 280710

- 5 HDMI Inputs to 1 HDMI Output
- High Speed Chip Set that Supports 3D, 4K x 2K
- Full HD1080P/60HZ
- HDCP Compliant
- Super IR control system, IR transport channel can be forward or backward, an IR adapter and a transmitter and receiver pigtailed are needed
- Supports Digital Audio Format, DTS-HD/Dolby-True HD/LPCM7.1/AC3/DTS/DSD
- Unique Circuit Design Allows for Protection against High Voltage and Peak Currents
- Tested for Compatibility with all leading HD Video brands
- Tested with Dolby 7.1 Home Theater Systems
- Smart switching technology
- Shelf Mounting
- 5V DC, UL Listed Power Supply for Transmitter
- Dimensions: 4.375"W x .875"H x 2.875"D

HDMI® 3 x 1 Switcher with IR Control

Part # 280711

- 3 HDMI Inputs to 1 HDMI Output
- High Speed Chip Set that Supports 3D, 4K x 2K
- Full HD1080P/60HZ
- HDCP Compliant
- Super IR control system, IR transport channel can be forward or backward, an IR adapter and transmitter and receiver pigtails are needed
- Supports Digital Audio Format, DTS-HD/Dolby-True HD/LPCM7.1/AC3/DTS/DSD
- Unique Circuit Design Allows for Protection against High Voltage and Peak Currents
- Tested for Compatibility with all leading HD Video brands
- Tested with Dolby 7.1 Home Theater Systems
- Smart switching technology
- Shelf Mounting
- 5V DC, UL Listed Power Supply for Transmitter
- Dimensions: 4.375"W x .875"H x 2.875"D

SPECIFICATIONS

HDMI version	HDMI v1.4 with 3D
HDCP version	HDCP1.2
Support HDMI resolution	1080P/1080i/720P/576i/480P/480i
Support video color bi.....	deep color 24bit/36bit
Support Audio Format	LPCM/Dolby-AC3/DTS7.1/DSD
Input Video signal	5.0Volts/P-P
Output cable distance.....	66 ft 24AWG Cable
Input cable distance.....	66 ft 24AWG Cable
Data transfer speed.....	6.75Gbps
Operating Humidity range	5 to 90%RH (No Condensation)
Operating Temperature range.....	15 to +55 Degrees C; 5 to 131 Degrees F
Power adapter format	Input AC (50Hz.60Hz) 100-240V
Power Supply	DC 5V

PACKAGE CONTENTS

Before attempting to use this unit, please check the packaging and make sure the following items are contained in the shipping carton:

- One HDMI Selector Switch
- Power Supply
- Product Manual
- Remote Control

CONNECT AND OPERATE

Connect the signal sources such as Blu-Ray Player, Play Station 3, audio/video receiver, cable or satellite receivers and computers equipped with HDMI output interfaces with a short high-speed HDMI cable to the HDMI Selector Switch inputs.

Connect the HDMI output from the Selector Switch to a high-definition display device such as HD-LCD, HD-DLP and HD projectors with HDMI input interfaces. Use high-speed HDMI cables that are recommended for the distances that are required for each connection.

These Selector Switches are powered by an external power supply which is included. Connect power first to the source, then to the Selector Switch and then to each HD TV or projector.

While playing HD audio and video content, turn on each HD TV set in order starting with that connected to output port 1 on the splitters and use the "Information" button on the remote to check for a 1080p/60 Hz, 120 Hz or 24 Hz resolution. If you have difficulty getting a picture, go to the TV's "set-up menu" and adjust the resolution. A 24 Hz vertical refresh rate may work better than a 60 Hz or higher, vertical refresh rate and is currently used for 3-D programming.

These units have the capability of being controlled via IR signals. The switch can be controlled from the display. This is accomplished by using an optional IR Receiver pigtail (Part # 280721) pointing away from the display(s), which can be connected with the optional HDMI IR Adapter (Part # 280703), and inserted between the HDMI cable connector and the display with the toggle switch at the "IR" position. The IR Transmitter pigtail (Part # 280720) is then connected to the switch and pointed at the source(s). A remote control is used at the display to select switch inputs and outputs.

CONNECTION DIAGRAM



Super IR Control System Over HDMI Cable

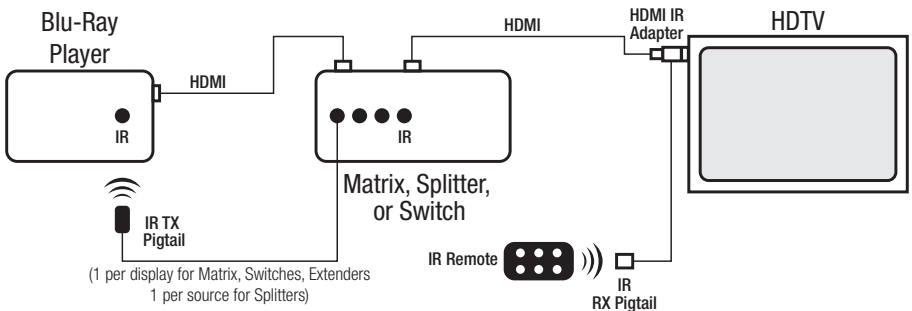

280710 PRODUCT IMAGES



280711 PRODUCT IMAGES



TROUBLE-SHOOTING

1. Best results are usually achieved when the source and display resolutions are the same. If resolutions differ, then the source and the display will try to adjust the signal to match the resolution of the HD TV with that of the source. This could result in a picture with a lower resolution on the other HD TV sets.
2. If you do not get audio and video see if you can use the "set-up" menu on the TV to adjust the audio settings and the video settings. If the HDMI control circuit can't establish a hand-shake, then there usually will be no audio or video and a blue or black screen with a statement like "this protocol not supported" or "weak signal".
3. If you get the above messages, re-set the Selector Switch by disconnecting the power supply. Alternately, you can disconnect all of the HDMI and power cables, wait 10 or 15 minutes for any voltages to decay and then connect all of the cables from the source to the display.
4. If you still have trouble, then try the "hot-plug concept. Turn-on the source and plug the HDMI cable to it and then power-up the Selector Switch and plug the cable into it, then plug the output cable into the display and turn-on the display and plug the HDMI cable from the Selector Switch into it. This activates all of the devices in order and results into a signal being plugged-in to a device that is on and will try to connect to the signal.
5. Most of the major player and display manufacturers employ a proprietary control channel to communicate between devices from the same manufacturer. Sometimes this can interfere with the HDMI control circuit or the authentication of the signal. Call the manufacturer if you experience this problem. Sometimes a player, an audio/video receiver, or a cable/satellite box may not have the latest software update and needs to have this downloaded from the manufacturer's web site.
6. If you have problems with the IR control circuit, make sure that the IR RX pigtail is plugged into the IR Adapter and the toggle is set at "IR". Check the batteries in the remote control that was supplied.

LIABILITY STATEMENT

Every effort has been made to ensure that this product is free of defects. The manufacturer of this product cannot be held liable for the use of this hardware or any direct or indirect consequential damages arising from its use. It is the responsibility of the user and installer of the hardware to check that it is suitable for their requirements and that it is installed correctly. All rights are reserved. No parts of this manual may be reproduced or transmitted by any form or means electronic or mechanical, including photocopying, recording or by any information storage or retrieval system without the written consent of the publisher.

Manufacturer reserves the right to revise any of its hardware and software following its policy to modify and/or improve its products where necessary or desirable. This statement does not affect the legal rights of the user in any way.

LIMITED WARRANTY

With the exceptions noted in the next paragraph, Vanco warrants to the original purchaser that the equipment it manufactures or sells will be free from defects in materials and workmanship for a period of one year from the date of purchase. Should this product, in Vanco's opinion, prove defective within this warranty period, Vanco, at its option, will repair or replace this product without charge. Any defective parts replaced become the property of Vanco. This warranty does not apply to those products which have been damaged due to accident, unauthorized alterations, improper repair, modifications, inadequate maintenance and care, or use in any manner for which the product was not originally intended.

Items integrated into Vanco products that are made by other manufacturers, notably computer hard drives and liquid crystal display panels, are limited to the term of the warranty offered by the respective manufacturers. Such specific warranties are available upon request to Vanco. A surge protector, power conditioner unit, or a uninterruptible power supply must be installed in the electrical circuit to protect against power surges.

If repairs are needed during the warranty period the purchaser will be required to provide a sales receipt or other acceptable proof of purchase to the seller of this equipment. The seller will then contact Vanco regarding warranty repair or replacement.

TECHNICAL SUPPORT

In case of problems, please contact Vanco Technical Support by e-mail at support@Vanco1.com or call 1-800-626-6445 between the hours of 8am and 5pm central US time zone on Monday through Friday.

When calling, please have the Model Number, Serial Number (affixed to the bottom of the unit) and Invoice available for reference during the call.

Please read this Instruction Manual prior to calling or installing this unit, since it will familiarize you with the capabilities of this product and its proper installation.

All active electronic products are 100% inspected and tested to insure highest product quality and trouble-free installation and operation. The testing process utilizes the types of high-definition sources and displays typically installed for entertainment and home theater applications.

For additional information, such as helpful installation videos, glossary of terms, etc. please visit www.vanco1.com

Vanco® International

506 Kingsland Drive
Batavia, Illinois 60510
call: 800.626.6445
fax: 630.879.9189
visit: www.vanco1.com